

APPLY LUBRICANT TO ALL SEALS  
PRIOR TO INSTALLATION.  
DO NOT USE SILICONE TYPE LUBRICANTS.  
FOR PROPER ARM MOUNTING SEE IS1505.

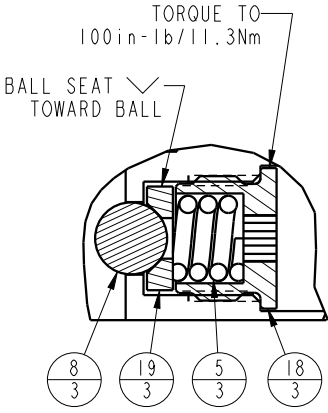

DETAIL A  
SCALE 1.500

No.	QTY	PART No.	DESCRIPTION	Std. Seal Kit	FKM Seal Kit	Spring Kit
N/A	N/A	IS1505	INSTRUCTION SHEET, ARM INSTALLATION			
N/A	N/A	61704033	SPRING KIT			
N/A	N/A	6V711043	SEAL KIT, FKM			
N/A	N/A	60711043	SEAL KIT, STANDARD			
27	1	39V11051	WIPER, PRESS-IN, (1-1/2)	X	X	
26	1	39H52001	SEAL, U-CUP, 1-3/4 x 3/16 x 2-1/8	X	39V52001	
25	1	39H51002	O-RING, (-033)	X	39V51002	
24	1	92090001	ASSY, BREATHER, SAE #4			
23	1	81592121	CAM, SC, LP, 7500/33KN, RH, TC			
22	1	81592100	DISK, Ø1.00 X .19			X
21	1	81542103	BASE, SC, BF, LP, 7500			
20	1	81532111	PLUG, SC, LP, 7500/33KN, SA, TC			
19	3	81532108	SEAT, BALL, SC, LP, TC			
18	3	81532107	RETAINER, SC, LP, TC			
17	1	81512110	PLUNGER, SC, LP, 7500/33KN, SA, TC			
16	1	39054018	BU RING, (-327)	X	X	
15	1	39054017	BU RING, (-033)	X	39054023	
14	1	39054016	BU RING, (1.5x.125x.063)	X	X	
13	2	39051041	O-RING, (-006)	X	39V51041	
12	2	39050042	O-RING, (-011)	X	39051025	
11	1	39011075	SEAL, LL, (1-1/2 X 1/8 X 1/8 1-3/4)	X	39V11075	
10	1	39001056	O-RING, (-119)	X	39V51014	X
9	1	30601144	PLUG, SOCH, SAE 4			
8	3	23650004	BALL, TUNGSTEN-CARBIDE .250			X
7	1	23600011	BALL, STEEL, ALLOY, .187			X
6	1	23350068	SPRING, COMPRESSION			
5	3	23350066	SPRING, COMPRESSION			
4	10	21500305	SHCS, M8 X 1.25-6G X 30MM			
3	2	21500200	WASHER			
2	3	21500031	SHCS, M5 X 0.8 X 14, ALY			
1	2	21500019	SCREW, CAP, BTNH, M3 X 6, ALY			

**PARTS LIST**



VEKTEK, INC.  
1334 E. SIXTH AVE. P.O. BOX 625  
EMPORIA, KS. 66801 U.S.A.

ASSEMBLIES AFFECTED  
14212100  
14212100F

SIZE A  
PL7171

REV D

D	5922	RELEASE	JDW	03/18/26
REV	IN ACCORDANCE WITH ECN	EFFECTIVE DATE	REVISED BY	DATE
DRW BY:	JDW	DRAWING STATUS: <b>Released</b>		
DATE:	6-17-11	PRODUCTION APPROVED FOR RELEASED STATUS ONLY		

SHEET 1 OF 1

